

- + Sello cartucho de fuelle elastomérico para el trabajo con hidrocarburos, soluciones acuosas y otros fluidos afines de gran aplicación en la industria en general.
- + Cartridge seal with elastomer bellows for hydrocarbons, water and other similar fluids in general industry.

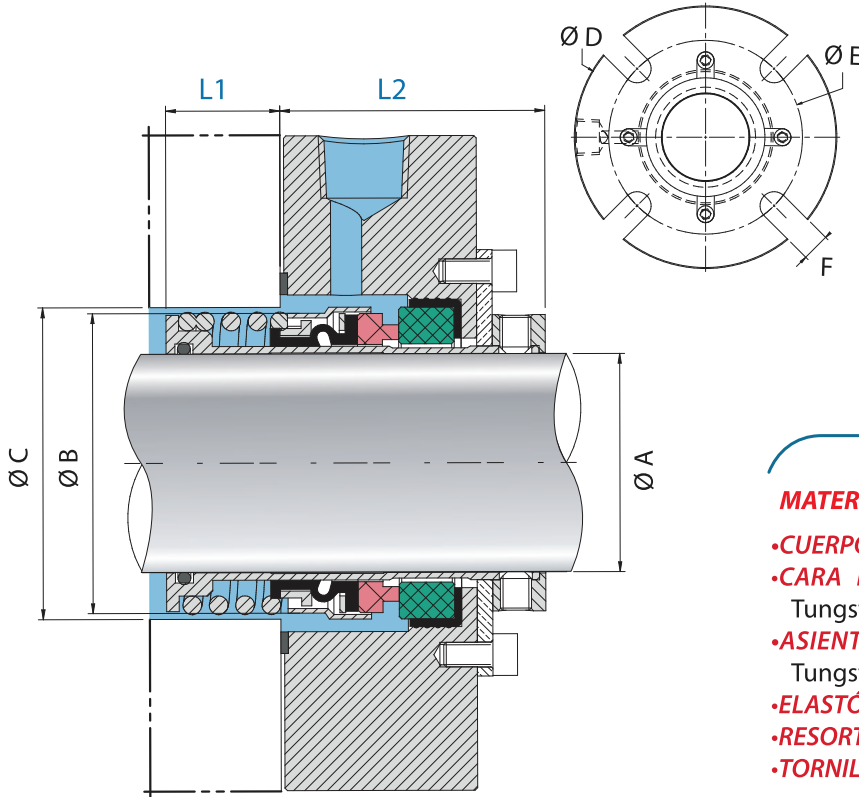

MATERIALES

- **CUERPO DEL SELLO:** AISI 316.
- **CARA ROTATORIA:** Carbón, Carburo de Silicio, Carburo de Tungsteno (Ni).
- **ASIENTO ESTACIONARIO:** Carburo de Silicio, Carburo de Tungsteno (Ni).
- **ELASTÓMEROS:** Viton®, EPR, Nitrilo.
- **RESORTE:** AISI 316, AISI 302.
- **TORNILLOS PRISIONEROS:** AISI 316.

MATERIALS

- **SEAL BODY:** AISI 316.
- **ROTARY FACE:** Carbon, Silicon Carbide, Tungsten Carbide (Ni).
- **STATIONARY SEAT:** Silicon Carbide, Tungsten Carbide (Ni).
- **ELASTOMERS:** Viton®, EPR, Nitrilo.
- **SPRING:** AISI 316, AISI 302.
- **SET SCREWS:** AISI 316.

VENTAJAS

- Repuestos de fácil adquisición.
- Trabaja en ambas direcciones.
- Brida universal.
- Autoalineante
- Adecuado para instalar en estopero estandar ANSI.

BENEFITS

- Easy repairable.
- Both direction working.
- Universal gland plate
- Self-aligning capability
- Suitable to install in ANSI standard bore

OPERATING RANGES

PRESSURE: Vacuum to 400 psig (27.5 bar)
TEMPERATURE: -20°F up to 400°F (-29°C up to 204°C)
Depending on the elastomer
VELOCITY: 4000 fpm (20m/s)

ØA	ØB	ØC		ØE	ØD	F	L1	L2
		Min.	Máx.					
1.000	1.375	1.500	1.889	2.805	4.000	0.525	0.785	1.954
1.125	1.500	1.625	2.015	2.933	4.125	0.525	0.533	2.062
1.250	1.687	1.812	2.294	3.213	4.250	0.525	0.656	2.062
1.375	1.812	1.937	2.421	3.338	4.375	0.525	0.563	2.062
1.500	2.000	2.125	2.680	3.599	4.875	0.525	0.835	2.125
1.625	2.125	2.250	2.812	3.766	5.000	0.562	0.897	2.125
1.750	2.250	2.375	2.918	3.875	5.250	0.562	0.913	2.125
1.875	2.375	2.500	2.918	3.875	5.250	0.562	0.913	2.125
2.000	2.687	2.750	3.015	4.000	5.500	0.562	1.141	2.312
2.125	2.812	2.875	3.360	4.469	5.859	0.687	1.141	2.312
2.250	2.750	2.875	3.485	4.566	6.500	0.687	1.266	2.312
2.375	3.062	3.125	3.610	4.719	6.500	0.687	1.002	2.466
2.500	3.250	3.375	3.891	5.000	6.750	0.687	1.266	2.563
2.625	3.500	3.625	4.062	5.170	6.750	0.687	1.478	2.500
2.750	3.500	3.625	4.062	5.170	6.750	0.687	1.478	2.500
2.875	3.625	3.695	4.186	5.312	7.000	0.687	1.478	2.500
3.000	3.937	4.000	4.469	5.720	7.750	0.812	1.610	2.562
3.125	4.062	4.125	4.600	5.845	7.875	0.812	1.625	2.562
3.250	4.062	4.125	4.600	5.845	7.437	0.812	1.677	2.510
3.375	4.312	4.375	4.825	6.095	8.125	0.812	1.813	2.562
3.500	4.437	4.500	4.975	6.220	8.250	0.812	1.782	2.562
3.625	4.562	4.625	5.100	6.250	8.375	0.687	2.063	2.562
3.750	4.632	4.724	5.199	6.770	8.750	0.687	1.875	2.562
3.875	4.812	4.905	5.375	6.636	8.750	0.812	1.938	2.562
4.000	4.937	5.031	5.500	6.761	9.000	0.812	2.250	2.562

Medidas en pulgadas / Dimensions in inches