

TIPO 424

SELLO EXTERNO PARA ABRASIVOS

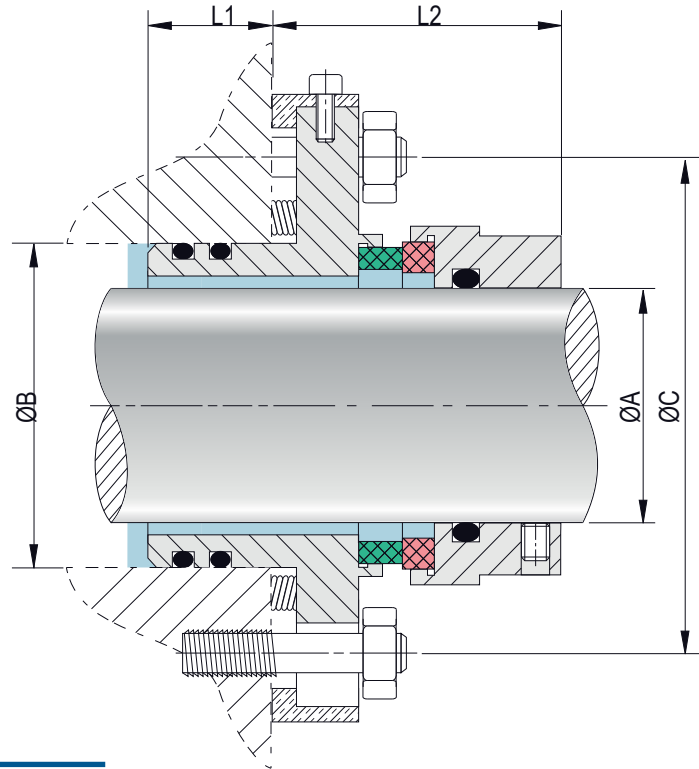

Sello externo para productos abrasivos, polvos, talcos y otros difíciles de sellar. De gran aplicación en la industria azucarera y en la mayoría de bombas industriales.

MATERIALES

- ▶ **CUERPO DEL SELLO:** AISI 316.
- ▶ **CARAS :** Carburo de Silicio (RB), Carburo de Tungsteno (Ni).
- ▶ **ELASTÓMEROS:** Viton®, EPR, Kalrez®, AFLAS®, Chemraz®.
- ▶ **RESORTES:** AISI 316, AISI 302
- ▶ **TORNILLOS PRISIONEROS:** AISI 316.

VENTAJAS

- ▶ Los resortes están aislados del fluido proceso.
- ▶ Es posible sellar fluidos que contienen sólidos.
- ▶ Adaptable a bombas ANSI.

EJE SHAFT ØA	DIÁMETRO CAJA CONTERBORE ØB		Ø CENTROS BOLT CIRCLE ØC		LONGITUD LENGTH L1		LONGITUD LENGTH L2	
	Inch	mm	Inch	mm	Inch	mm	Inch	mm
1"	1.625	41.28	2.812	71.42	0.625	15.88	1.500	38.10
1 1/8"	1.750	44.45	2.812	71.42	0.625	15.88	1.500	38.10
1 1/4"	1.875	47.63	3.125	79.38	0.625	15.88	1.500	38.10
1 3/8"	2.000	50.80	3.125	79.38	0.625	15.88	1.500	38.10
1 1/2"	2.187	55.55	3.437	87.30	0.625	15.88	1.500	38.10
1 5/8"	2.375	60.33	3.437	87.30	0.625	15.88	1.500	38.10
1 3/4"	2.500	63.5	3.687	93.65	0.625	15.88	1.500	38.10
1 7/8"	2.625	66.68	3.687	93.65	0.625	15.88	1.500	38.10
2"	2.750	69.85	4.125	104.78	0.875	22.23	1.750	44.45
2 1/8"	2.875	73.03	4.125	104.78	0.875	22.23	1.750	44.45
2 1/4"	3.000	76.20	4.437	112.70	0.875	22.23	1.750	44.45
2 3/8"	3.125	79.38	4.437	112.70	0.875	22.23	1.750	44.45
2 1/2"	3.250	82.55	4.687	119.05	0.875	22.23	1.750	44.45
2 5/8"	3.500	88.90	4.687	119.05	0.875	22.23	1.750	44.45

Medidas en pulgadas / Dimensions in inches

▶ RANGOS DE OPERACIÓN

PRESIÓN	Vacío a 200 psig (14 bar)
VELOCIDAD	2950 fpm (15m/s)
TEMPERATURA	-20°F hasta 450°F (-29°C hasta 232°C) dependiendo del elastómero