



II ZGD c T5



KS Q ISO 9001 : 2009 / ISO 9001: 2008

MAX DYNAMIC[®] COUPLING

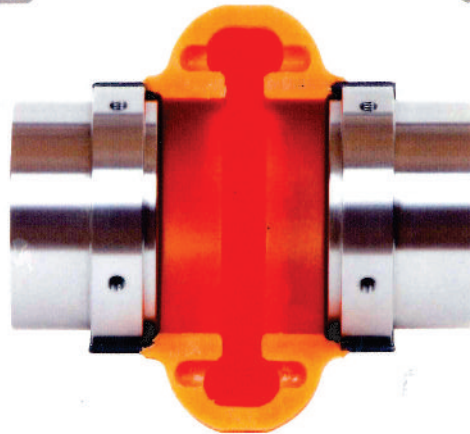

MAX DYNAMIC[®] COUPLING

Since 1999, WooJin Industry co. has developed and manufactured Polyurethane flexible coupling exclusively in Korea and supply Standard and Spacer type of the coupling through our overseas business division, FNC TRADING CO., LTD. from 2004.

Thanks to our efforts to improve quality and to support customers and market requirements, we succeeded to develop "HS" type and "HT" type newly.

The MAX DYNAMIC[®] HS coupling (blue) is specifically designed for hot and humid conditions and HT coupling (red) torque ratings is about 30% higher and torsional stiffness is 45% higher than standard coupling.

The MAX DYNAMIC[®] coupling is a unique general purpose Elastomeric coupling with Split-In- Half element and interchangeable with Hubs suitable for reducing total cost by reducing inventory and assembly time.

To improve productivity and efficiency in power transmission process, MAX DYNAMIC[®] coupling will provide superior products for your industrial applications. We, WOOJIN Industry co. and FNC TRADING CO., LTD are ready to work for customers to save and reduce maintenance cost, installation cost, and time.

We have CE ATEX certificate (II2GD c T5) for HS and HT coupling to meet customers' various applications and requirements.

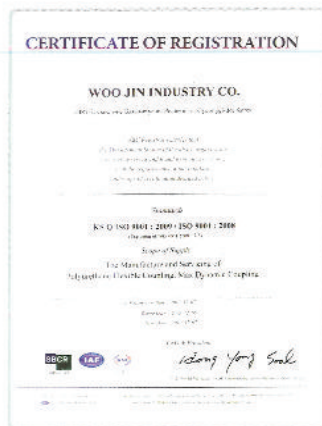

MAX DYNAMIC[®] COUPLING



■ Characteristics of MAX DYNAMIC[®] Coupling

1. Facility protection for twirl, twist, impact, and abrasion.
2. Very simple replacement and maintenance without any oil or grease.
3. Very simple replacement without the separation of motor or connector on the related line due to its simple structure.
4. Possible for the dissimilar connection and assembly with the same hub.
5. Polyurethane based for good water and chemical resistance.
6. Highest flexible elasticity on run.
7. Less noise.

■ Application

- | | | |
|-------------------|------------------------|------------------------|
| ■ AGITATOR | ■ FANS | ■ PULP & PAPER MILL |
| ■ BLOWER | ■ GENERATORS | ■ RUBBER INDUSTRY |
| ■ COMPRESSOR | ■ PUMP | ■ STEEL INDUSTRY |
| ■ CONVEYORS | ■ BREWERY & DISTILLING | ■ TEXTILE MILLS |
| ■ CRANES & HOISTS | ■ FOOD INDUSTRY | ■ AGGREGATE PROCESSING |
| ■ ELEVATORS | ■ LUMBER INDUSTRY | ■ CEMENT |

MAX DYNAMIC[®] STANDARD coupling

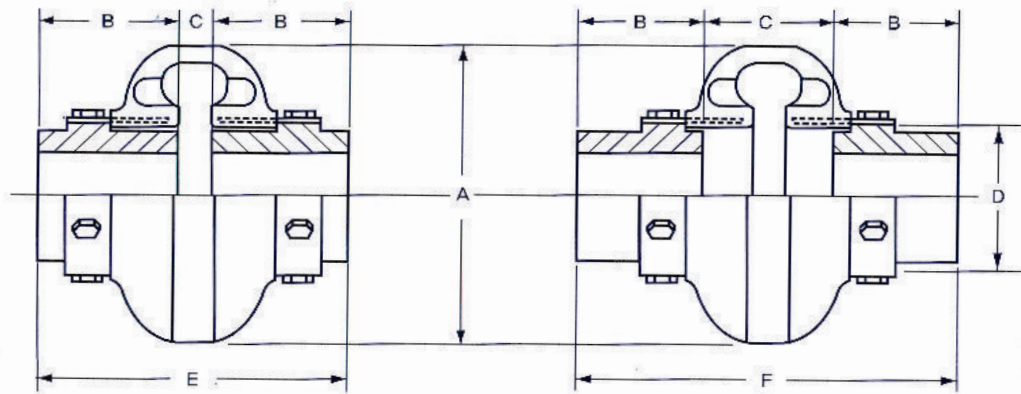
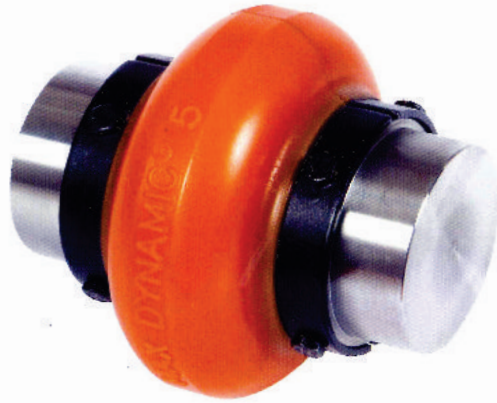

MAX DYNAMIC [®] COUPLING NO.	Torque (N.m)	Max. Bore (mm)	Max. rpm	Power Rating (kw/rpm)	Dimensions in mm							Weight (kg)		
					A	B	C		D	E		F	Element only	*SSH only
					out dia	hub length	Min. shaft spacing	Max. shaft spacing	hub dia	Total Length				
									in	out				
D-2	21.58	28	7,500	0.0023	89	24	35	47	47	83	95	0.34	0.52	
D-3	41.20	34	7,500	0.0043	102	37	9	47	59	83	121	0.42	1.27	
D-4	62.78	42	7,500	0.0066	116	37	9	47	66	83	121	0.47	1.66	
D-5	107.91	48	7,500	0.0110	137	45	10	52	80	100	142	0.85	3.23	
D-10	163.83	55	7,500	0.0170	162	45	11	53	93	101	143	1.15	4.30	
D-20	261.93	60	6,600	0.0270	184	50	15	63	114	115	163	1.61	6.86	
D-30	413.00	75	5,800	0.0430	210	56	12	68	138	124	180	2.42	10.58	
D-40	621.95	85	5,000	0.0660	241	61	12	74	168	134	196	3.08	17.20	
D-50	865.24	90	4,200	0.0900	279	69	12	86	207	150	224	4.09	24.24	
D-60	1,412.64	105	3,800	0.1480	318	80	11	99	222	171	259	6.67	32.72	
D-70	2,491.74	120	3,600	0.2620	356	85	18	109	235	189	281	8.64	38.47	
D-80	4,463.55	155	2,000	0.4670	406	114	17	149	286	245	377	13.15	89.65	
D-100	9,613.80	171	1,900	1.0000	533	140	44	95	359	324	375	29.50	154.50	
D-120	19,237.41	190	1,800	2.0000	635	152	57	124	448	362	429	49.00	234.00	

*SSH : Straight Standard Hub (No Keyway, Not Bored)

MAX DYNAMIC® SPACER coupling

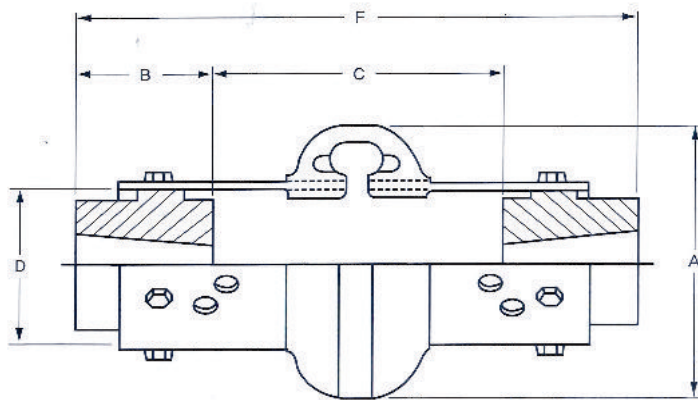

MAX DYNAMIC® COUPLING NO.	Torque (N.m)	Max. Bore (mm)	Max. rpm	Power Rating (kw/rpm)	Dimensions in mm							Weight (kg)
					A	B	C		D	F		Element only
							out dia	hub length		Min. shaft spacing	Max. shaft spacing	
DS-2	21.58	28	7,500	0.0023	89	24	91	100	47	146	149	0.74
DS-3	41.20	34	7,500	0.0043	102	37	85	140	59	184	216	1.10
DS-4	62.78	42	7,500	0.0066	116	37	85	140	66	184	216	1.18
DS-5	107.91	48	7,500	0.0110	137	45	89	140	80	184	228	1.73
DS-10	163.83	55	7,500	0.0170	162	45	89	140	93	184	228	2.17
DS-20	261.93	60	4,800	0.0270	184	50	67	180	114	238	280	2.56
DS-30	413.00	75	4,200	0.0430	210	56	54	180	138	238	293	4.18
DS-40	621.95	85	3,600	0.0660	241	61	41	180	168	238	307	5.02
DS-50	865.24	90	3,100	0.0900	279	69	28	180	207	238	319	6.94
DS-60	1,412.64	105	2,800	0.1480	318	80	66	250	222	318	415	11.80
DS-70	2,491.74	120	2,600	0.2620	356	85	59	250	235	318	421	13.94
DS-80	4,463.55	155	1,800	0.4670	406	114	37	250	286	318	478	16.40

※ RING : DS-2~DS-10 Only

MAX DYNAMIC[®] HS coupling

for hot and humid conditions



II 2GD c T5

- Newly developed for hot and humid conditions and superior than standard coupling
- Simple assembly and disassembly
- User-friendly interchangeable with existing hubs
- Materials are hydrolytically stable

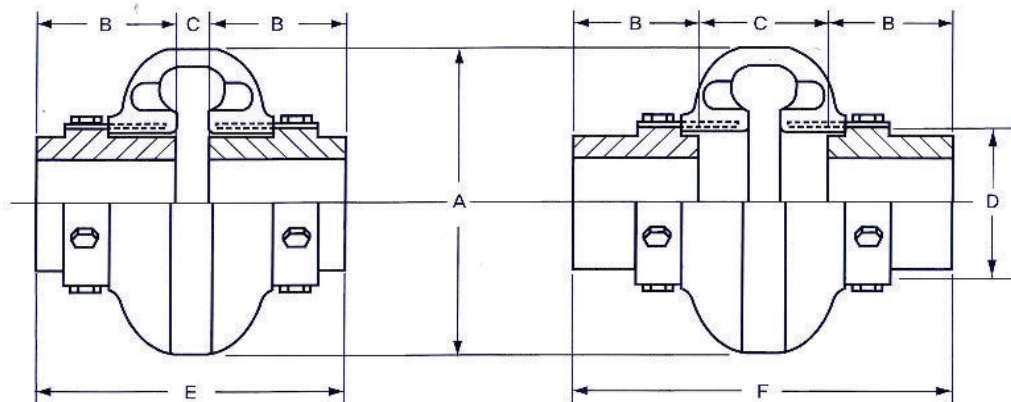

MAX DYNAMIC [®] COUPLING NO.	Torque (N.m)	Max. Bore (mm)	Max. rpm	Power Rating (kw/rpm)	Dimensions in mm							Weight (kg)
					A	B	C		D	E		
					out dia	hub length	Min. shaft spacing	Max. shaft spacing	hub dia	Total Length		
									in	out	Element only	
D-2HS	21.58	28	7,500	0.0023	89	24	35	47	47	83	95	0.34
D-3HS	41.20	34	7,500	0.0043	102	37	9	47	59	83	121	0.42
D-4HS	62.78	42	7,500	0.0066	116	37	9	47	66	83	121	0.47
D-5HS	107.91	48	7,500	0.0110	137	45	10	52	80	100	142	0.85
D-10HS	163.83	55	7,500	0.0170	162	45	11	53	93	101	143	1.15
D-20HS	261.93	60	6,600	0.0270	184	50	15	63	114	115	163	1.61
D-30HS	413.00	75	5,800	0.0430	210	56	12	68	138	124	180	2.42
D-40HS	621.95	85	5,000	0.0660	241	61	12	74	168	134	196	3.08
D-50HS	865.24	90	4,200	0.0900	279	69	12	86	207	150	224	4.09
D-60HS	1,412.64	105	3,800	0.1480	318	80	11	99	222	171	259	6.67
D-70HS	2,491.74	120	3,600	0.2620	356	85	18	109	235	189	281	8.64
D-80HS	4,463.55	155	2,000	0.4670	406	114	17	149	286	245	377	13.15
D-100HS	9,613.80	171	1,900	1.0000	533	140	44	95	359	324	375	29.50
D-120HS	19,237.41	190	1,800	2.0000	635	152	57	124	448	362	429	49.00

MAX DYNAMIC® HT coupling

for high torque and torsional stiffness



II 2GD c T5

- HT coupling torque ratings is about 30% higher and torsional stiffness is 45% higher than standard coupling
- Simple assembly and disassembly
- User-friendly interchangeable with existing hubs

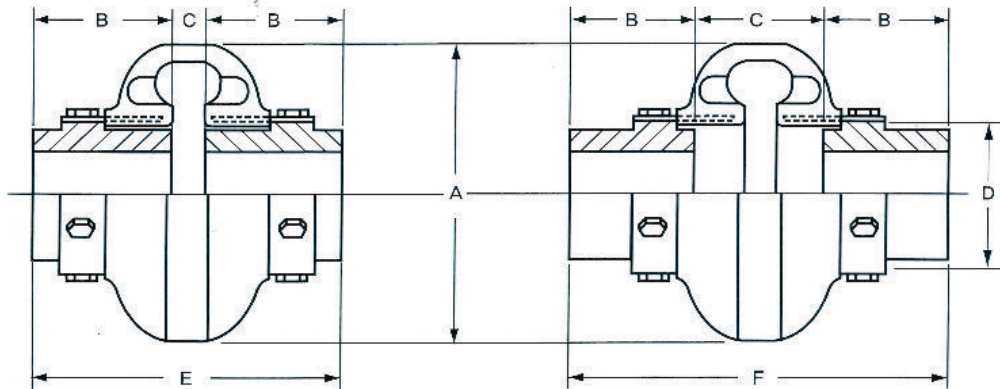

MAX DYNAMIC® COUPLING NO.	Torque (N.m)	Max. Bore (mm)	Max. rpm	Power Rating (kw/rpm)	Dimensions in mm							Weight (kg)
					A	B	C		D	E		
					out dia	hub length	Min. shaft spacing	Max. shaft spacing	hub dia	Total Length		
D-2HT	27.47	28	7,500	0.0029	89	24	35	47	47	83	95	0.34
D-3HT	52.97	34	7,500	0.0055	102	37	9	47	59	83	121	0.42
D-4HT	81.42	42	7,500	0.0085	116	37	9	47	66	83	121	0.47
D-5HT	140.28	48	7,500	0.0147	137	45	10	52	80	100	142	0.85
D-10HT	212.88	55	7,500	0.0223	162	45	11	53	93	101	143	1.15
D-20HT	340.41	60	6,600	0.0356	184	50	15	63	114	115	163	1.61
D-30HT	536.61	75	5,800	0.0561	210	56	12	68	138	124	180	2.42
D-40HT	808.34	85	5,000	0.0846	241	61	12	74	168	134	196	3.08
D-50HT	1,124.23	90	4,200	0.1176	279	69	12	86	207	150	224	4.09
D-60HT	1,834.47	105	3,800	0.1919	318	80	11	99	222	171	259	6.67
D-70HT	3,237.30	120	3,600	0.3387	356	85	18	109	235	189	281	8.64
D-80HT	5,787.90	155	2,000	0.6055	406	114	17	149	286	245	377	13.15
D-100HT	12,450.00	171	1,900	1.2316	533	140	44	95	359	324	375	29.50
D-120HT	24,525.00	190	1,800	2.5657	635	152	57	124	448	362	429	49.00

*Spacer type of HT coupling is available.

MAX DYNAMIC[®] STANDARD COUPLING with Compression Bushed Hubs

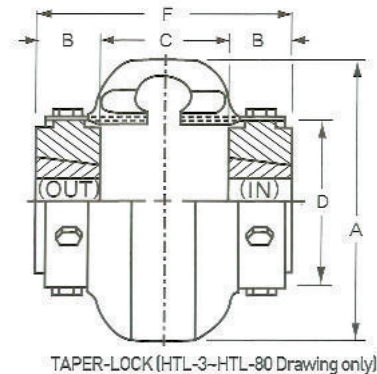
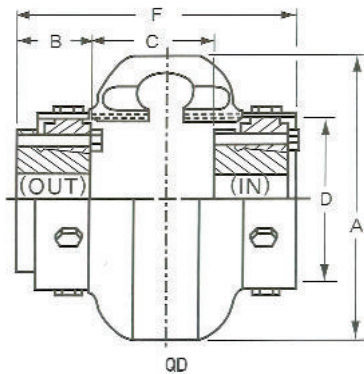

• Specification Data With QD Hubs

MAX DYNAMIC [®] Coupling No.	QD Bush No.	Torque (N.m)	Max. Bore (mm)	Max. rpm	Power Rating (kw/rpm)	Dimensions in mm						Weight (kg)	
						A	B	C		D	F		
						Out Dia	Hub Length	In	Out	Hub Dia	Total Length		In
D-4	JA	62.78	30	7,500	0.0066	116	25	31	48	66	82	99	0.95
D-5	SH	107.91	35	7,500	0.0110	137	32	44	48	80	108	114	1.63
D-10	SDS	163.83	42	7,500	0.0170	162	33	30	59	93	97	125	2.18
D-20	SK	261.93	55	6,600	0.0270	184	48	16	67	114	108	162	3.86
D-30	SF	413.00	60	5,800	0.0430	210	51	37	56	138	138	157	6.35
D-40	E	621.95	75	5,000	0.0660	241	67	32	44	168	165	178	10.80
D-50	E	865.24	75	4,200	0.0900	279	67	35	73	207	168	207	17.06
D-60	F	1,412.64	90	3,800	0.1480	318	92	38	48	222	222	232	20.64
D-70	J	2,491.74	100	3,600	0.2620	356	114	33	36	235	262	265	30.89
D-80	M	4,463.55	140	2,000	0.4670	406	171	19	32	286	362	375	63.50
D-100	M	9,613.80	140	1,900	1.0000	533	173	44	29	359	390	375	113.40
D-120	N	19,237.41	150	1,800	2.0000	635	206	44	29	448	456	441	215.46

*Note : Dimensions may vary depending on bushing manufacturer. Dimensions subject to change.

• Specification Data With TAPER-LOCK Hubs

MAX DYNAMIC [®] Coupling No.	Taper Lock Bush No.	Torque (N.m)	Max. Bore (mm)	Max. rpm	Power Rating (kw/rpm)	Dimensions in mm						Weight (kg)	
						A	B	C		D	F		
						Out Dia	Hub Length	In	Hub Dia	Total Length	In		Out
HTL-3	1008	41.20	25	7,500	0.0043	102	22	43.0	59	87	87	0.82	
HTL-4	1008	62.78	25	7,500	0.0066	116	22	43.0	66	87	87	1.18	
HTL-5	1108	107.91	28	7,500	0.0110	137	22	56.0	80	100	100	1.81	
HTL-10	1310	163.83	35	7,500	0.0170	162	25	52.0	93	103	103	2.72	
HTL-20	1610	261.93	42	6,600	0.0270	184	25	63.5	114	114	114	4.08	
HTL-30	2012	413.00	50	5,800	0.0430	210	32	65.0	138	129	129	6.17	
HTL-40	2517	621.95	65	5,000	0.0660	241	44	60.0	168	149	149	9.89	
HTL-50	2517	865.24	65	4,200	0.0900	279	44	76.0	207	165	165	14.29	
HTL-60	3020	1,412.64	75	3,800	0.1480	318	51	84.0	222	186	186	21.14	
HTL-70	3535	2,491.74	100	3,600	0.2620	356	89	60.0	235	238	238	30.25	
HTL-80	4040	4,463.55	100	2,000	0.4670	406	102	95.0	286	298	298	37.19	
								In	Out		In	Out	
HTL-100	4545	9,613.80	110	1,900	1.0000	533	114	38	152	359	267	381	113.40
HTL-120	5050	19,237.41	125	1,800	2.0000	635	127	51	181	448	305	435	185.07

*Note : Dimensions subject to change.

• Recommended Capscrew

No.	Torque		No.	Torque	
	kgf.m	N.m		kgf.m	N.m
D-2	2.3	22.56	D-20	4.1	40.22
D-3					
D-4					
D-5					
D-10					
D-60	10.2	100.06	D-100	37.7	369.84
D-70					
D-80					
D-120					

- NOTE**
1. A bolt having the highest tension should be used.
 2. Lockite as an adhesive should be used.
 3. A bolt should never be used twice.
 4. Never treat a bolt with oil.

• The tolerance of installation

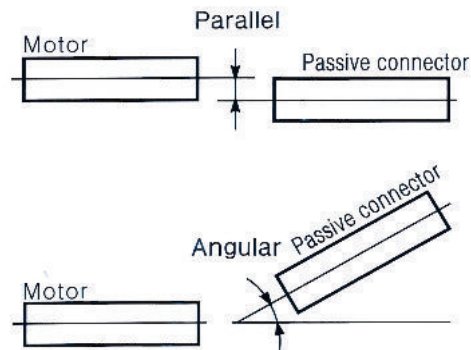
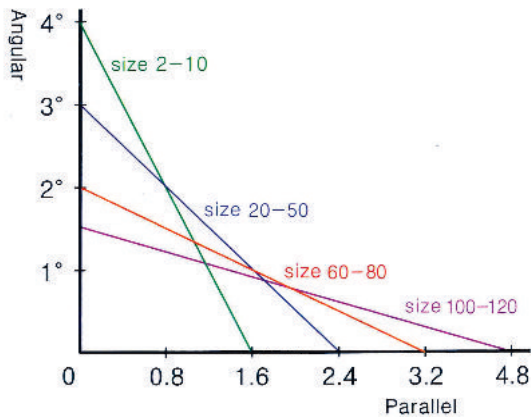

• The method of assembly

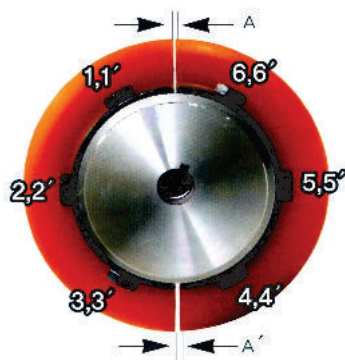

1. Adjust the face of A and A' at same space.
2. Adjust Hub's Minimum space.
3. Assemble the bolts in the order of 2-2', 5-5', 3-3', 4-4', 6-6'.
4. Assemble the bolts in the middle part of the edge

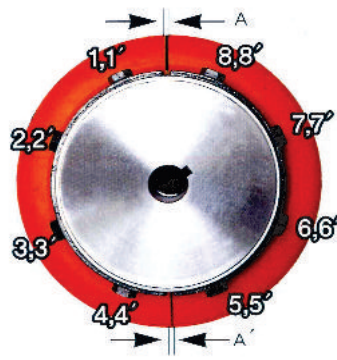

1. Adjust the face of A and A' at the same space.
2. Adjust Hub's Minimum space.
3. Assemble the bolts in the order of 2-2', 7-7', 3-3', 6-6', 1-1', 4-4', 8-8', 5-5'.
4. Assemble the bolts in the middle part of the edge.

● Service(safety) factors for each running parts

General Application	Service Factor	Industry Application	Service Factor
Agitator	1.5	Aggregate Processing Cement	2.0~3.0
Blower	1.0~1.5	Brewery & Distilling	1.0~2.0
Compressor	1.0~2.0	Food Industry	1.0~2.0
Conveyor	1.25~1.5	Lumber Industry	1.5~2.5
Cranes & Hoist	2.0~2.5	Power Industry	1.0~2.5
Elevators	1.0~2.0	Pulp & Paper Mills	1.0~3.5
Fans	1.0~2.0	Rubber Industry	1.0~3.0
Generators	1.0~2.5	Steel Industry	2.0~4.5
Pumps	1.0~1.5	Textile	1.0~2.0

● Service/Safety Factor

Running status		Service Factor
1	For being continuous running and light load weight	1.0
2	For being the various change of the rotary power	1.5
3	For being various and frequent variation on the turning force	2.0
4	For being the variation of the rotary power accompanying impact	2.5
5	For being high impact load-weight accompanying slight retro-rotation	3.0
6	For being frequent retro-rotation accompanying high impact	consult



MAX DYNAMIC® Coupling Installation Instructions

• Step to install

Step 1

- Inspect both shafts (driven & driving) and hub bores and confirm they are clean and no dirty particle or burrs.
- Be sure they keys fit shafts properly.
- Mount both hubs to the shafts securing only one hub while the other side hub should be loose for minor adjustment of spacing.
- In case tapered being used, follow bushing manufacturer's instructions is required.
- If hub is bored for an interference fit, we would like to recommend heating the hub in water, oil bath or an oven and after heating, immediately positioning it on the shaft.
- Be careful Spot heat may cause distortion.

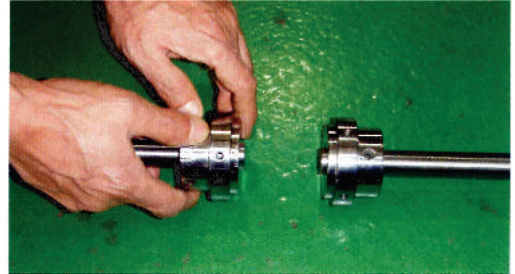

Step 2

- Place half of the element around hubs and secure with capscrews provided.
- The element will space the other hub. It is important to have capscrew properly tightened.
- For placing proper capscrew, see Table 1 on Installation Instructions for recommended capscrew torques and instructions.
- Now secure the other hub to the shaft.

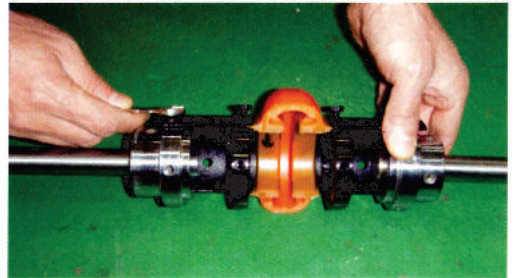

Step 3

- Mount other half of the element to hubs.
- Tighten all capscrews to the recommended capscrew torques in Table 1 on Installation

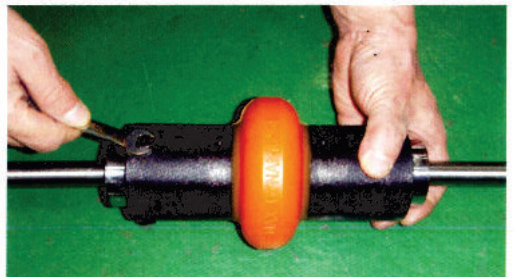

* Above shown Spacer type coupling installation ; the same procedure applies for the standard, HT, and HS type coupling.

* Helpful tip

If the capscrew holes in the element do not line up with the hubs properly due to equipment misalignment, please rotate the shafts as you can install each capscrew. For larger couplings, first install the capscrew that is positioned in the center of the half element.

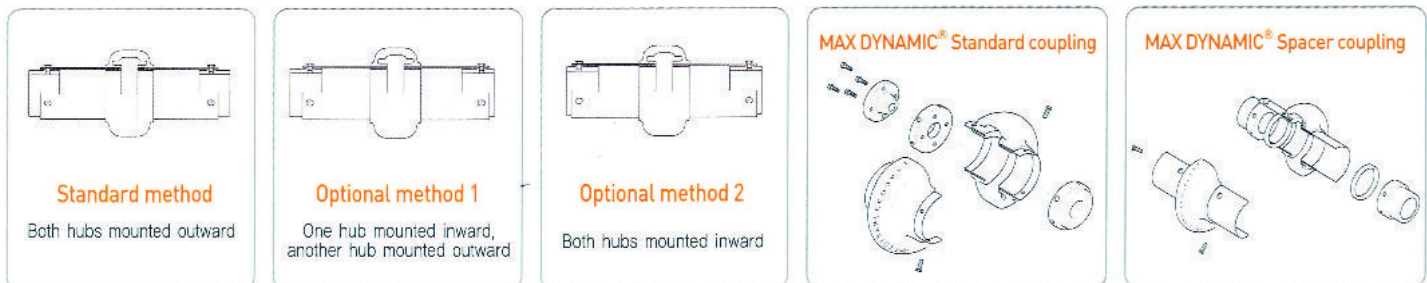



Factory
WOO JIN INDUSTRY CO.

481-7, Gasan-Ri, Gasan-Myeon, Pocheon-Si,
Gyeonggi-Do, 487-810, KOREA
Tel : +82-31-542-2871
Fax : +82-31-542-2864
Website: www.woo-jinco.com

Overseas Business Div.

FNC TRADING CO., LTD.

C-306, 227, Wonhyoro, Yongsan Gu, Seoul,
140-767, KOREA
Tel : +82-2-753-2313
Fax : +82-2-753-2855
E-mail : fnc4you@yahoo.co.kr